

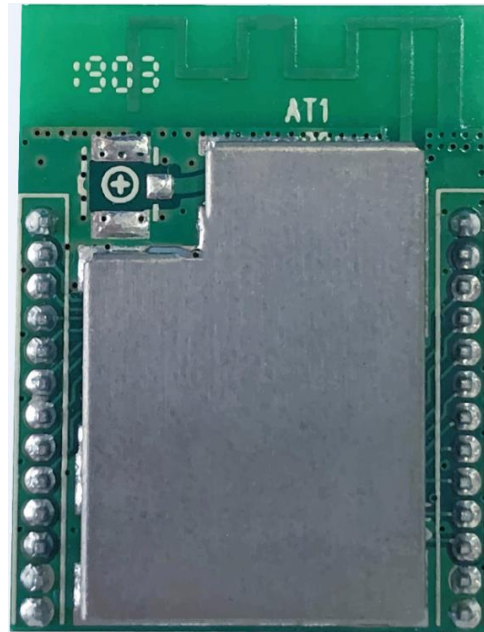

GL-EFR32S/GL-EFR32H is a dual-protocol supportable BLE/Zigbee module, with exquisite size and could support on-board antenna & low power mode, could be widely used in Smart Home/Smart Building/IoT fields.

Product no.: GL-EFR32S/GL-EFR32H

Spec. sheet version: 20190411

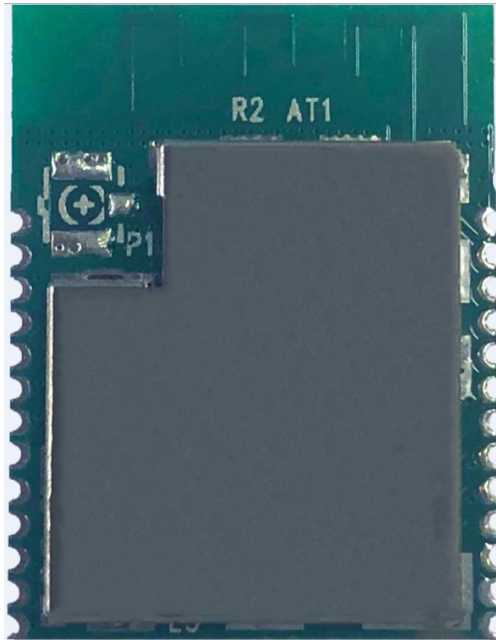

Product Features:

- **SW & HW support**
 - Based on proven Silicon Labs chipset
 - Support BLE5.1
 - Support Zigbee module switch by Software updating
 - Support low power mode
 - On-board antenna inclusive

Product General Description	2
Hardware Specification	3
Hardware Specification	3
Hardware Block Diagram	4
Circuit Interface	4
System Mapping Table	6
Software Specification	7
Software functions	7
Product Certificates	8

Product General Description

GL-EFR32S/GL-EFR32H is a newly developed BLE/ZIGBEE module, based on proven Silicon Labs chipset, low power consumption, multi-protocol supportable (BLE and Zigbee could switch by SW updating), and on-board antenna supportable.

Wide application scenarios as below:

- ✓ IoT multi-protocol devices
- ✓ Smart Home
- ✓ Lighting
- ✓ Health monitoring products
- ✓ Measuring equipment
- ✓ Products on Building automation and Security

Hardware Specification

Item	Spec.
Product name	Bluetooth & Zigbee Module
Model	GL-EFR32S/GL-EFR32H
CPU	Silicon Labs EFR32MG1P232F256GM48-CR0
Protocol	Support Zigbee、BLE
Storage	RAM:32KB/ Flash:256KB
Tx Power	19 dBm
Antenna	On-board antenna (external antenna IPEX reserved)
Internal Interface	17*GPIO (could be configured to UART、SPI、JTAG、I2C, etc.)
Module interface type	Stamp interface/Pin interface
Supply voltage	3.3V
Power Consumption	support low power consumption, standby power < 50uW
Module dimension	25mm*20mm
Operating temperature	0°C~75°C
Storage temperature	-40°C~85°C
Operating humidity	10%~90%

Hardware Structure

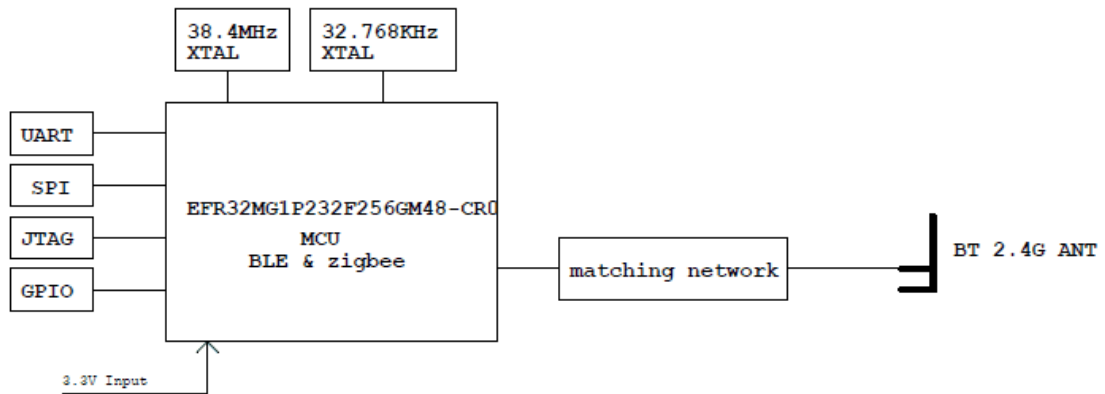

Circuit Interface

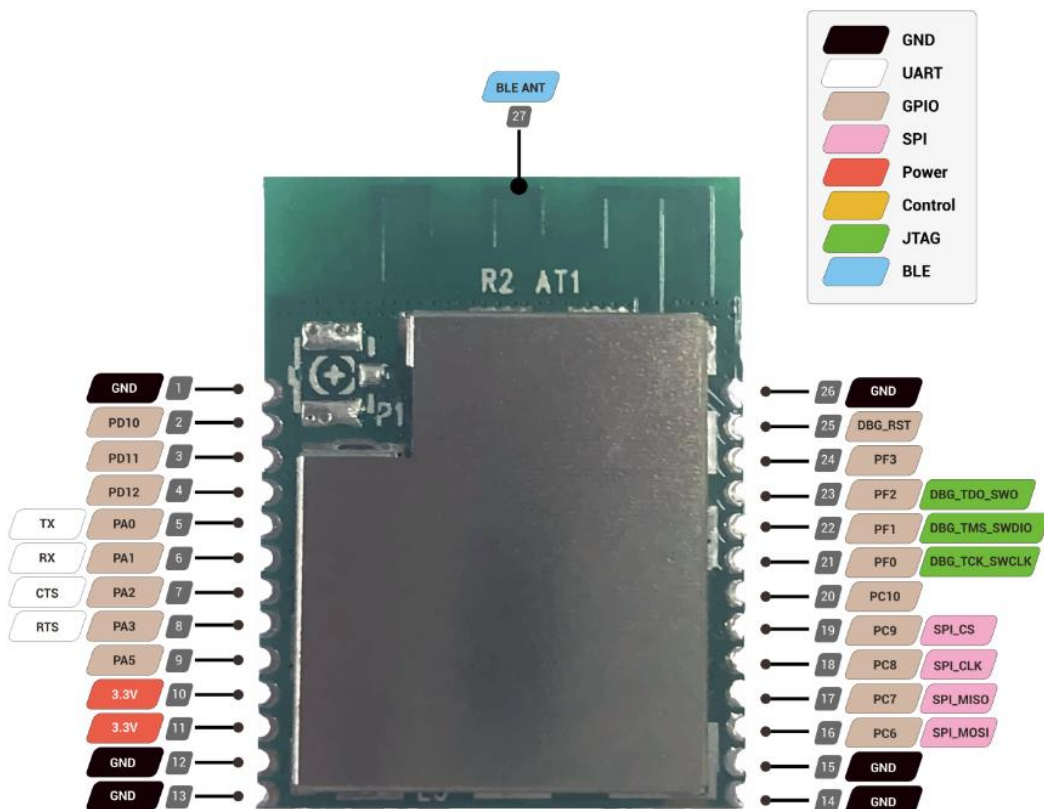

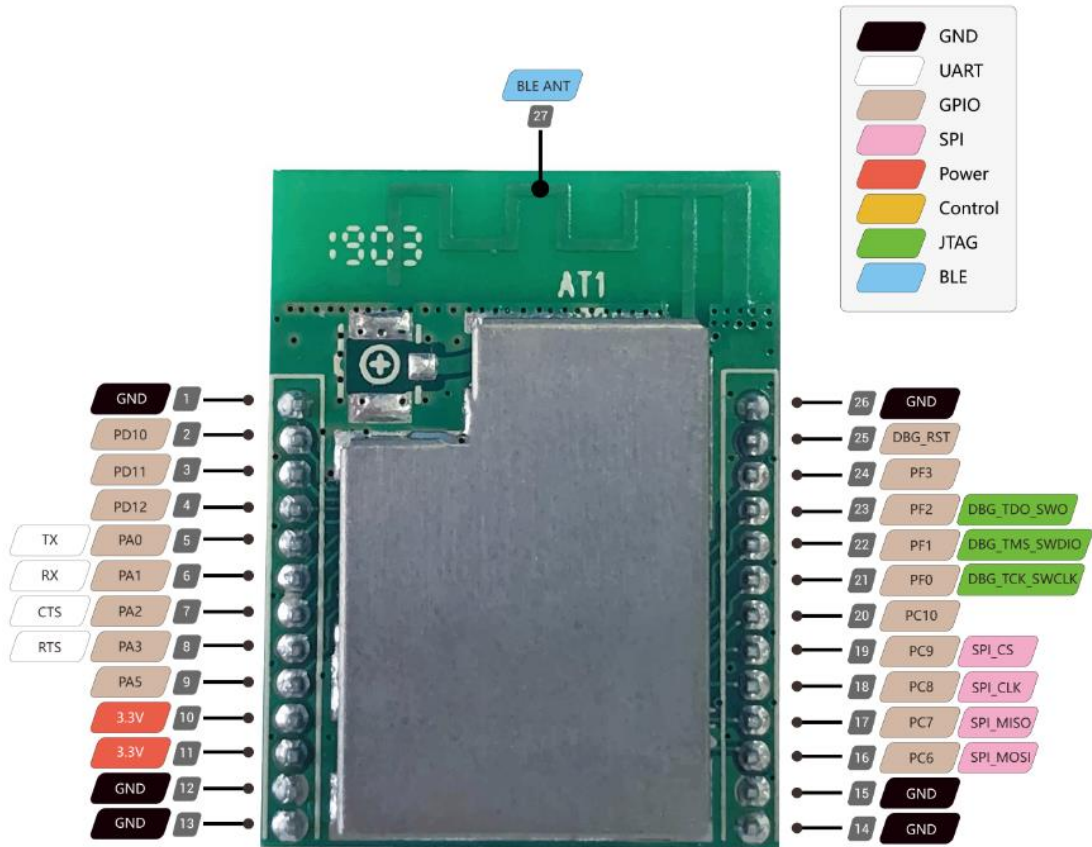

System IO Mapping Table

IO Mark	Default function	Remark
PA0	UART_TX	serial interface output
PA1	UART_RX	serial interface input
PA2	CTS	serial interface flow control
PA3	RTS	serial interface flow control
PA5	VCOM_ENABLE	serial interface enable
PC6	SPI_MOSI	SPI interface
PC7	SPI_MISO	
PC8	SPI_CLK	
PC9	SPI_CS	
PC10	ZB_Request	Zigbee PTA interface
PD10	NCP_nHOST_INT	Zigbee module enable
PD11	NCP_nWAKE	Zigbee module wake-up
PD12	ZB_Priority	Zigbee PTA interface
PF0	DBG_TCK_SWCLK	DEBUG burner clock line
PF1	DBG_TMS_SWDIO	DEBUG burner USB cable
PF2	DEBUG_TDO_SWO	DEBUG burner USB cable
PF3	ZB_Grant	Zigbee PTA interface
DBG_RST	Reset	Module reset

Software Specification

Software Functions

Bluetooth Low Energy

(Current version Bluetooth 5.1)

Used as central device

- Scan BT broadcast
- Support scan requirement report
- Connect to BT device
- Read & write eigenvalue of remote device
- Receive Notify and Indicate
- Support AES-128, AES-256, ECC,SHA-1,SHA-2 encrypted transmission
- Support max 8 connections simultaneously
- Support 2M-PHY high-speed transmission
- Support local UART updating

Used as peripheral device

- User-defined BT broadcast content
- User-defined BT broadcast interval
- Support BT broadcast extension
- User-defined GATT service content
- Support Notify and Indicate
- Support AOA BT location
- Support OTA updating

Zigbee (Current version ZigBee 3.0)

Zigbee network

- Coordinator, Router, End-device supportable
- CBA, GP,HA,HC,LO,SE,TA,ZCL6,ZLL and such profile supportable
- User-defined Zigbee network setup and quit
- Network PANID, channel, TX power dynamic revisionment
- Permit other device to access network, custom network access interval
- Support Centralized key, installed code, Distribute code secret key exchange modes
- Support dynamic updating of network secret key
- Support AES-128, AES-256, ECC, SHA-1, SHA-2 and such encrypted transmission
- Support remote device binding
- Support single-point transmission, multicast and broadcast
- Support local updating of UART/SPI and remote updating of OTA

Certification

Type	Remark
ROHS	support
CE	support
FCC	support
US California 65	support

CE

The GL-EFR32S/GL-EFR32H modules are in conformity with the essential requirements and other relevant requirements of the Radio Equipment Directive (RED). Please note that every application using the GL-EFR32S/GL-EFR32H will need to perform the radio EMC tests on the end product according to EN 301 489-17. Separate RF testing is not required provided that the customer follows the module manufacturer's recommendations and instructions and does not make modifications, e.g. to the provided antenna solutions or requirements.

GL-EFR32S/GL-EFR32H module is in conformity with the essential requirements and other relevant requirements of the Radio Equipment Directive (RED) at nominal 10 dBm transmit power.

The transmit power of the module is not limited and when an end product is using GL-EFR32S/GL-EFR32H, the end product manufacturer is responsible that the end product is in conformity of all relevant requirements of the RED.

FCC Statement

This device complies with part 15 of the FCC rules. Operation is subject to the following two conditions: (1) this device may not cause harmful interference, and (2) this device must accept any interference received, including interference that may cause undesired operation.

Changes or modifications not expressly approved by the party responsible for compliance could void the user's authority to operate the equipment.

NOTE: this equipment has been tested and found to comply with the limits for a Class B digital device, pursuant to part 15 of the FCC Rules. These limits are designed to provide reasonable protection against harmful interference in a residential installation. This equipment generates uses and can radiate radio frequency energy and, if not installed and used in accordance with the instructions, may cause harmful interference to radio communications. However, there is no guarantee that interference will not occur in a particular installation. If this equipment does cause harmful interference to radio or television reception, which can be determined by turning the equipment off and on, the user is encouraged to try to correct the interference by one or more of the following measures:

-
- Reorient or relocate the receiving antenna.
 - Increase the separation between the equipment and receiver.
 - Connect the equipment into an outlet on a circuit different from that to which the receiver is connected.
 - Consult the dealer or an experienced radio/TV technician for help.

Important Note:

Radiation Exposure Statement

This equipment complies with FCC radiation exposure limits set forth for an uncontrolled environment. This equipment should be installed and operated with minimum distance 20 cm between the radiator and your body.

This transmitter must not be co-located or operating in conjunction with any other antenna or transmitter. Country Code selection feature to be disabled for products marketed to the US/Canada.

1. The antenna must be installed such that 20 cm is maintained between the antenna and users, and
2. The transmitter module may not be co-located with any other transmitter or antenna.

As long as the three conditions above are met, further transmitter testing will not be required. However, the OEM integrator is still responsible for testing their end-product for any additional compliance requirements required with this module installed.

Important Note:

In the event that these conditions cannot be met (for example certain laptop configurations or co-location with another transmitter), then the FCC authorization is no longer considered valid and the FCC ID cannot be used on the final product. In these circumstances, the OEM integrator will be responsible for re-evaluating the end product (including the transmitter) and obtaining a separate FCC authorization.

End Product Labeling:

The final end product must be labeled in a visible area with the following "Contains FCC ID: 2AFIW-SH32BZ"

If the FCC identification number is not visible when the module is installed inside another device, then the outside of the device into which the module is installed must also display a label referring to the enclosed module. This exterior label can use wording such as the following; Contains Transmitter Module FCC ID: 2AFIW-SH32BZ.

Manual Information to the End User:

The OEM integrator has to be aware not provide information to the end user regarding how to install or remove this RF module in the user's manual of the end product which integrates this module.

The end user manual shall include all required regulatory information/warning as show in this manual.

When the module is installed inside another device, the user manual of this device must contain below warning statements;

1. This device complies with part 15 of the FCC rules. Operation is subject to the following two conditions:
 - 1) this device may not cause harmful interference,

-
- 2) this device must accept any interference received, including interference that may cause undesired operation.
 2. Changes or modifications not expressly approved by the party responsible for compliance could void the user's authority to operate the equipment. The devices must be installed and used in strict accordance with the manufacturer's instructions as described in the user documentation that comes with the product.

Shenzhen Guanglianzhitong Tech Co.,Ltd

Room 305-306, Skyworth Digital, Songbai road, shiyan street,

Baoan District, Shenzhen, China

Email: sales@gl-inet.com

Tel: +86-755-86606126

Website: www.gl-inet.com